

Opportunities at



aapm&r

2792
ATTENDEES

90%
OF ATTENDEES
ARE AAPM&R
MEMBERS

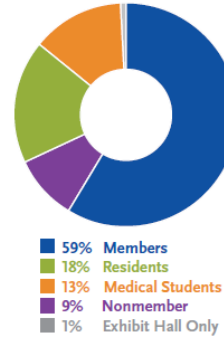

23% HOLD A SUBSPECIALTY CERTIFICATION

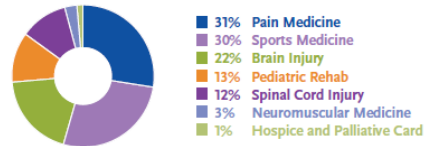

PRIMARY PRACTICE SETTING



94%

OF ATTENDEES
WOULD RECOMMEND
THE ANNUAL ASSEMBLY
TO THEIR PEERS

498

RESIDENTS ATTENDED
THE ASSEMBLY

96%

OF ATTENDEES
VISIT THE
PM&R PAVILION

**THE BEST IN
EDUCATION**

75+
EDUCATIONAL
SESSIONS

14
3-HOUR, HANDS-ON
SKILLS LABS

4
PLENARY
SESSIONS

12
CLINICAL AND
PRACTICE THEMES

**All data taken from the Annual Assembly Attendee Demographics Report, Exhibitor Survey and Attendee Survey.*

Registration numbers based on #AAPMR2019 (Live meeting).

Opportunities from #AAPMR19 in San Antonio



Opportunities at #AAPMR20 (Virtual)

New Announcement

Come prepared for the Job and Fellowship Fair, Nov 13 at 6 pm (CT). This handout (also found at the Member Resource Center) will tell you how to upload your CV and apply for a job opening!

[Dismiss](#) [LINK](#)

Welcome to the Theater

Sponsored Education Theater and Product Demonstrations

- Elevating the Standard of Care for Patients with Lower Limb Amputation (Sponsored by JFK Johnson Rehabilitation Institute)**
11/14/2020 3:15PM - 3:45PM
[Watch On Demand](#)
- ITB Therapy Dosing Strategies (Sponsored by Medtronic)**
11/14/2020 3:14PM - 3:15PM
[Watch On Demand](#)
- REAL: Transforming the Rehabilitation Journey (Sponsored by REAL)**
11/13/2020 3:15PM - 3:45PM
[Watch On Demand](#)
- Clinical Application of Robotics in Neuro Rehabilitation (Sponsored by Moss Rehab)**
11/13/2020 3:00PM - 4:00PM
[Watch On Demand](#)

ITB Therapy Dosing Strategies (Sponsored by Medtronic)
11/14/2020 3:14PM - 3:15PM
[Watch On Demand](#)

Christina Hardesty, MD

VIRTUAL aapm&r ANNUAL ASSEMBLY NOVEMBER 8-15, 2020

LOG IN NOW!
AAPMR

Welcome to the virtual 2020 Annual Assembly. To log in, use the same email and password (both lowercase) that you would use to sign into aapmr.org. Contact the Academy at (847) 737-6000 or info@aapmr.org if you need help with your login credentials.

Email Address:

[FORGOT PASSWORD?](#)

[If you receive an "Already Logged In" message, wait 1 minute before re-entering.](#)

[Privacy Policy](#)

[Terms Of Use](#)

[Computer Tips](#)

[Login Help](#)

This page is sponsored by

Exhibit Hall Entrance

Sponsored Education Theater AND Product Demonstrations
[ENTER THEATER](#)

Exhibit Hall Hours
Friday, 10 am - 4 pm (CT)
Saturday, 10 am - 4 pm (CT)
Sunday, 10 am - 2 pm (CT)

Exhibit Hall 1 BOOTHS A-E

Exhibit Hall 2 BOOTHS F-L

Exhibit Hall 3 BOOTHS M-Q

Exhibit Hall 4 BOOTHS R-Z

[aapm&r Registry](#)

[AAPM&R Career Corner](#)

Exhibit Hall 1—Booths A-E

MERZ

DEDICATED TO ADVANCING UNIQUE THERAPEUTIC TREATMENTS

Visit the MERZ THERAPEUTICS Virtual Booth to learn more.

#AAPMR21 Important Locations

- Convention Center: [Nashville Music City Center](#), 201 Rep. John Lewis Way S, Nashville, TN 37203
- Exhibit Hall: Nashville Music City Center – Halls A&B, Level 3
- Registration: Level 2
- Job and Fellowship Fair: Hall A, Level 4
- Meeting Rooms: Levels 1, 2 and 4
- General Session: Karl F. Dean Grand Ballroom, Level 4
- Headquarter Hotel: [Omni Nashville Hotel](#)

** All Locations are subject to change.*

Sponsorship Opportunities at #AAPMR21

Be the First to Reach Attendees

Your Opportunity...

Before #AAPMR21

- Registration Confirmation Email

- Sponsor's logo will appear on the confirmation email that is sent once an attendee registers. The logo can link to the sponsor's site.

Opportunity Cost: \$10,000

- Know Before You Go Email

- Sponsor Logo will appear on the know before you go email sent to all pre-registered attendees prior to #AAPMR21. This email illustrates meeting highlights (i.e., activities, destinations and logistical information that will make their meeting most memorable). Sponsor logo can link to the sponsor's site.

Opportunity Cost: \$10,000

Your Opportunity... Before, During and After #AAPMR21

- Main Mobile App Sponsor

Corporate logo on splash page, on the rotating banner and on prominent signage plus recognition in *Official Program* and AAPM&R website. One push notification directing attendees to your booth or other activity each day.

Opportunity Cost: \$30,000

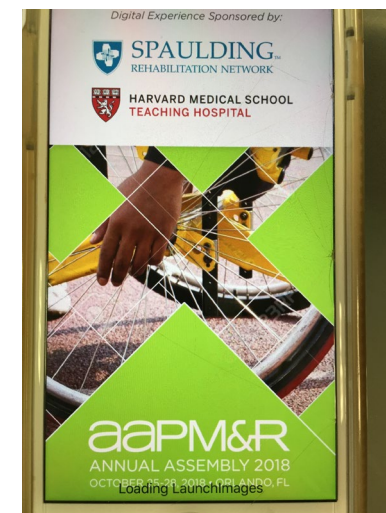

85% of Attendees
download the mobile app.

As more attendees make use of the mobile app, your exposure will increase.

Your Opportunity... at #AAPMR21

- Attendee Registration Bag

- Corporate Logo(s) on each bag plus recognition in *Official Program*, Mobile App, and AAPM&R Signage

Opportunity Cost: \$35,000

- Lanyards

- Corporate logo on each lanyard given to all attendees, plus recognition in *Official Program* and Mobile App

Opportunity Cost: \$30,000

- Hotel Room Drop

- Have your flyer delivered to all attendees staying at the headquarter hotel (OMNI Nashville Hotel)

Opportunity Cost: \$8,000



Your Opportunity... To Keep Attendees Safe

- Personal Card-Sized Hand Sanitizer

2,000 sanitizers will be distributed to attendees at registration, plus an additional 1,000 to be placed at the Member Solution Center.

Opportunity Cost: \$12,500

- Safety Bags

The safety bag is a plastic bag containing 4 face masks and hand sanitizer. Your logo will be included on the bag and hand sanitizer. An estimated 2,000 to be placed at registration and distributed to attendees.

Opportunity Cost: \$17,500



2021 REHAB 5K RUN/WALK & ROLL

Every year, the Foundation for PM&R hosts a 5K event in conjunction with the AAPM&R Annual Assembly. This is a great opportunity to increase your exposure in a unique way and build good will in the physiatry community. Recognition is throughout the year and includes:

- This event will be held live and virtually – expanding the audience.
- Your company will be cited as the sponsor in all race-related promotions. You will also be featured in all communications with participants, from the registration confirmation email to reminders leading up to race day and in the final announcement of the race results.
- Your sponsorship will also be listed in all meeting-related Academy publications that promote the Rehab 5K, further broadening your exposure to the physiatry community.
- There will be a leader board on the Foundation website that will be updated with results as they come in during the week of the meeting; your company name will be included on the board.
- Every race participant will receive a commemorative t-shirt with your corporate logo.
- Your sponsorship will be included in the Foundation UPDATE newsletter, the Annual Report, and will also appear on the Foundation website.

Only one corporate sponsor will be accepted.

Opportunity Cost: \$8,500

ADVERTISING

Print Advertising – Annual Assembly Publications

- AAPM&R distributes 2 publications for the Annual Assembly each year

aapm&r

ANNUAL ASSEMBLY 2021

NOVEMBER 11-14 • NASHVILLE, TN

Package Options

(Your ad will be included in both the Preliminary and Official Program)

FULL PAGE	U.S. \$7,500
INSIDE FRONT COVER	U.S. \$18,000
INSIDE BACK COVER	U.S. \$18,000
BACK COVER	U.S. \$26,000
COVER TIP	U.S. \$30,000

A La Carte Options

(choose which publication to include your ad)

	PRELIMINARY PROGRAM*	OFFICIAL PROGRAM*
FULL PAGE	U.S. \$4,550	U.S. \$3,550
INSIDE FRONT COVER	U.S. \$10,000	U.S. \$10,000
INSIDE BACK COVER	U.S. \$10,000	U.S. \$10,000
BACK COVER	U.S. \$14,000	U.S. \$14,000
COVER TIP	U.S. \$16,000	U.S. \$16,000

Preliminary Program Distribution
10,000+

Official Program Distribution
3,000+

[Here](#) is a link to the 2021 Media Kit.

aapm&r

Opportunities at #AAPMR21

Inside the Convention Center

Entrance Escalators and Banner

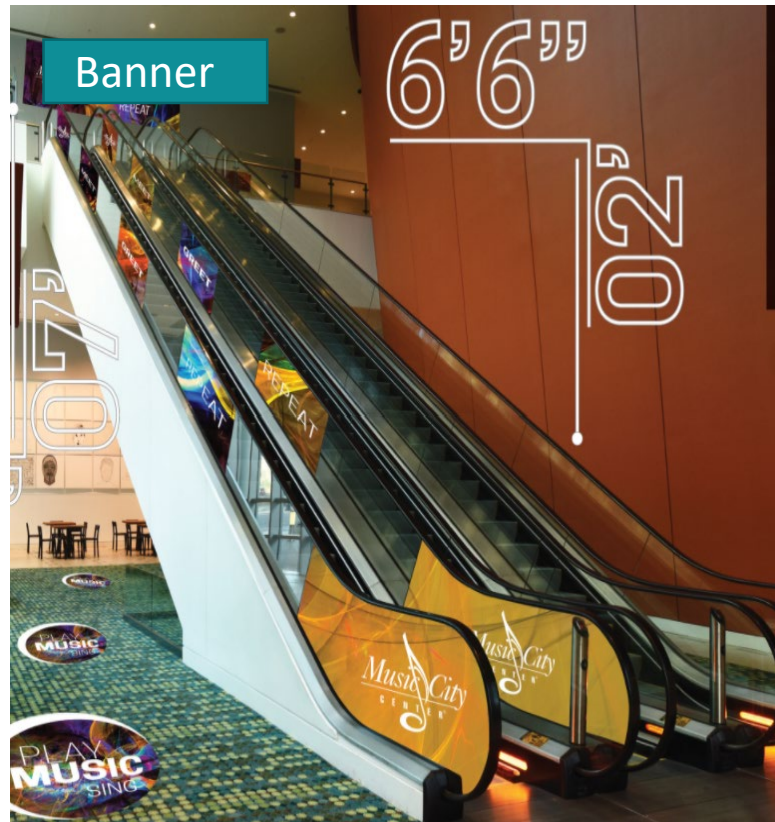

Two banks of escalators will be used to bring attendees up and down the 4 levels of the Convention Center at #AAPMR21. In addition to escalator clings, a banner opportunity exists at the top of each escalator bank.

Escalator Dimensions:

- Single 6'6" x 2'
- 1 set on one level
- 1 down escalator and 1 up (12 panels)

Opportunity Cost: 1 set \$14,500

Double sided cost increases to \$17,500

Add a second set for an additional \$12,000

Banner Dimensions: Opportunity Cost: \$12,500

- Single sided
- 10' x 3'

Floor Clings

Directional floor clings placed strategically throughout the convention center with your logo and booth number.

Floor Cling Dimensions

- 20 clings
- approximate size 4'x4'

Opportunity Cost: \$13,500



Larger floor clings placed in high traffic areas. An example of placement, outside Hall A1 which will be the entrance to the Job Fair on Wednesday; once the Job Fair has ended, it will be the entrance to the Exhibit Hall Thursday-Sunday.

Floor Cling Dimensions

- 1 cling
- Size: 8' x 10'

Opportunity Cost: \$10,000

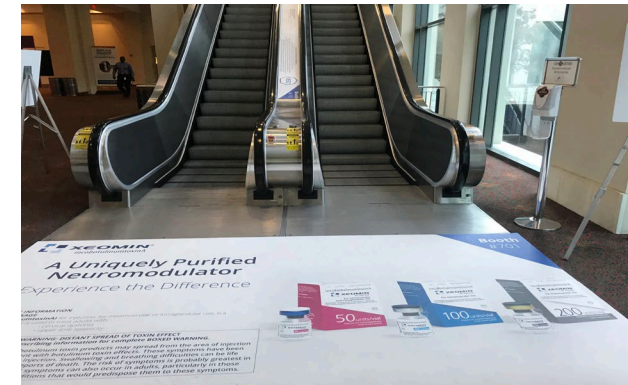

Clings on Glass Railing



Attendees will pass these railings multiple times over the 4 days of the Annual Assembly. Railings are on Level 2 of the Convention Center where the session rooms are located.

Railing Dimensions:

- Single sided
- Size: 52"x32"
- Up to 12 clings

Opportunity Cost: \$15,000

Message in Motion

- Your message will be seen by all attendees, each of the 4 days on the Message in Motion video wall. This 38' long electronic video wall will be placed in a high traffic area and run *continuously* for 4 days of the meeting.

As a 60 Second Video Sponsor, you will be able to speak directly to Annual Assembly Attendees. Your video message will rotate within a 10-minute loop continuously for 4 days of the meeting running ~288 times during the meeting (i.e., 288 **full minutes** of animated communication to our PM&R specialists!).

Opportunity Cost: \$9,500



Banner Opportunity – Outside Hall B



This banner will hang above the main entrance of Exhibit Hall B.

Banner Dimensions:

- Single sided
- 7'5" x 14'10"

Opportunity Cost: \$14,500

This can also be a digital opportunity.

Meet Up Zone

New in 2021 Meet Up Opportunities! A place where attendees can gather while social distancing. Located outside of the exhibit hall in the third-floor lobby.

Includes:

- 2 Column Wraps with your graphics and booth number
- 2 Meter Boards
- 6 Table Logos
- Messaging in Mobile app and the Know Before you Go email

Opportunity Cost: \$15,000



Additional Signage Opportunities

- **4-Sided Kiosk**
 - Get your message seen in all directions!
Opportunity Cost: \$10,000
- **Light Box**
 - Light up your message!
Opportunity Cost: \$8,500
- **Meter Boards**
 - One or a series to tell a story!
Opportunity Cost: \$5,500

AAPM&R will place the signage in high traffic areas.

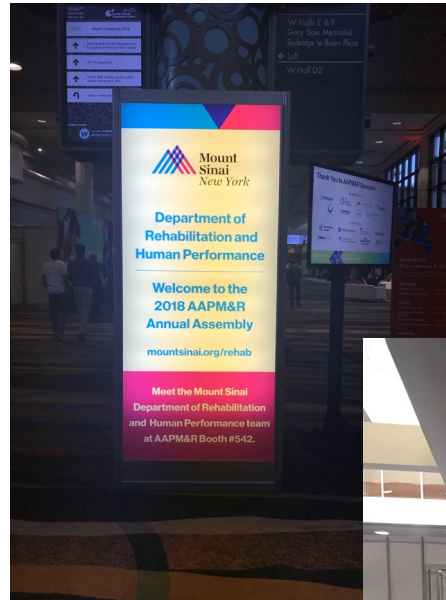

Banner – Inside Exhibit Hall

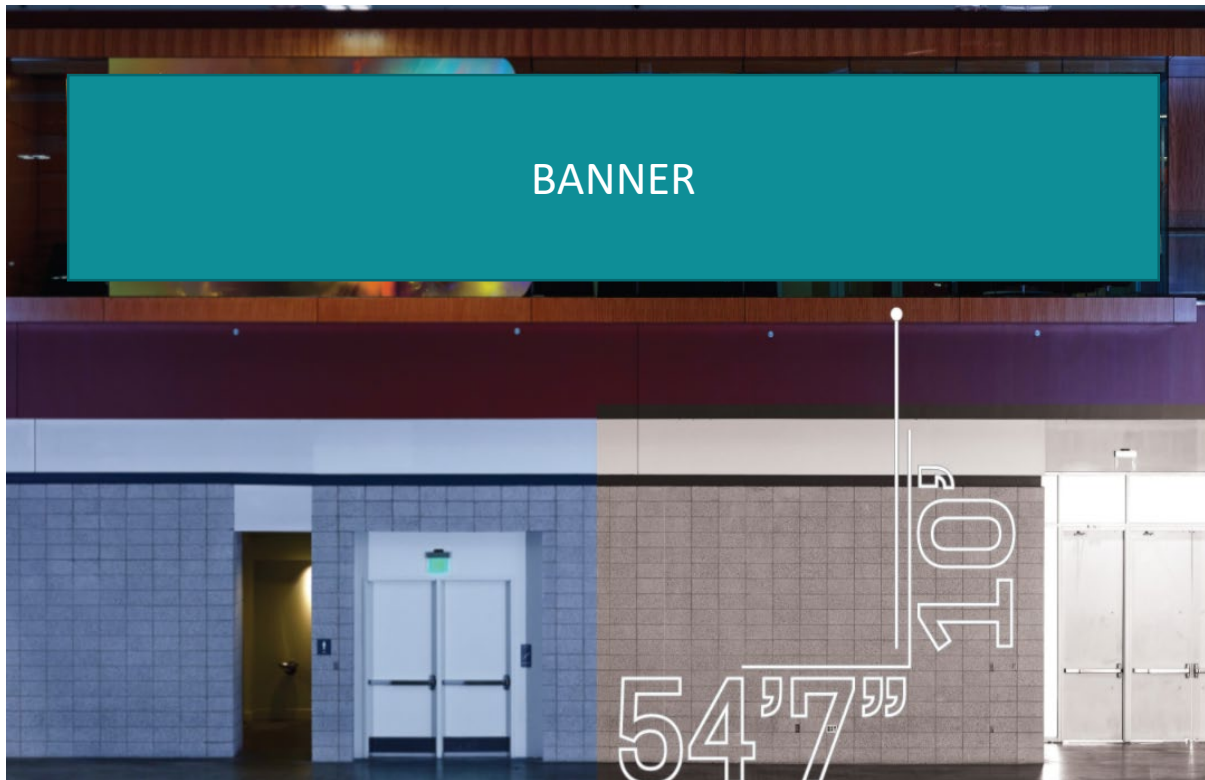

This banner will hang above one of the main entrances, inside the exhibit hall.

Dimensions:

- Single sided
- 54'7" x 10'

Opportunity Cost: \$18,500

Business Suites

Create a Private Exhibitor Suite

Order your Exhibitor Business Suite to create your *private* office right on the exhibit floor

- **Exhibitor Suite includes:**
- Available Thursday through Sunday
- Space rental
- Fabric (Velcro ready) panels
- Sign (14"x22") with company name or company logo
- Carpet (13 oz.) and first night vacuuming
- Installation and dismantling labor
- Furniture Package Available
- **Order by September 30, 2021**

Prices starting at \$4,495 for a 10x10.

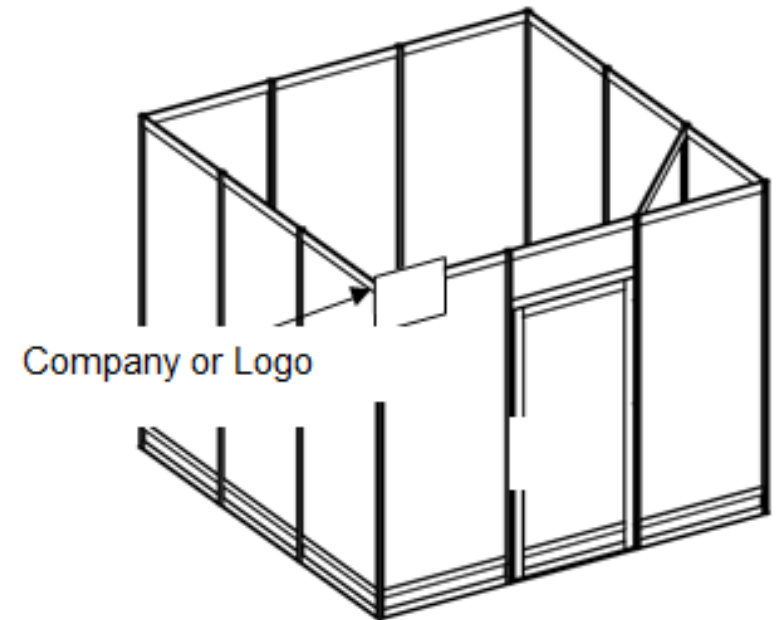

Opportunities at #AAPMR21

Digital Opportunities

Your Opportunity... To Go Digital

Several digital opportunities exist within the Nashville Music City Center. Digital Ads are for a rotating 10 second slide or can be bought out.

Outside of Exhibit Hall B, one of the primary entrances to the exhibit hall.

Size	156"
Pixel Dimensions	576x1152
Image format	.png, .jpeg
Video Format	.mp4

10 second slide	\$6,000
Buy-Out the unit	\$15,000



Video Walls

65" video wall displays located throughout the Convention Center.

Size	10' x 5'6"
Pixel Dimensions	1920x1080
Image format	.png, .jpeg
Video format	.mp4

Opportunity cost: \$7,500 per screen exclusive



Located on the entrance wall of 5th and Demonbreun, one of two entrances



Located outside of Exhibit Hall A2, near the entrance to Hall B and at the Job and Fellowship Fair entrance

Own the Digital Outside the General Session Ballroom

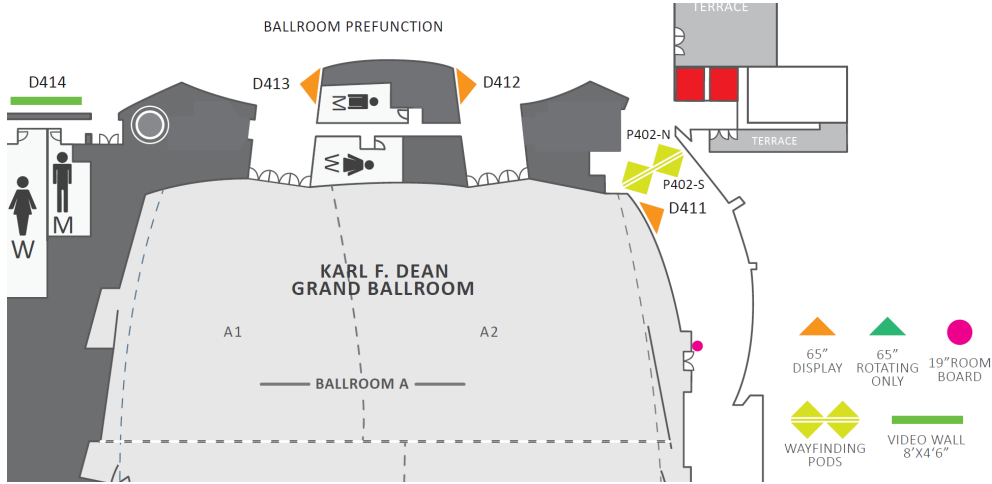

Located on the 4th level of the convention center, there are 4, 65" displays, 1 Video Wall, plus 2 wayfinder pods (contact for full details).

Opportunity cost: \$30,000

Opportunities at #AAPMR21

Education Opportunities

Your Opportunity... To Educate #AAPMR21 Attendees

Educate
Physiatrists
in the format
of
YOUR CHOICE!

	Education Theater	Innovation Stage	Center Stage	Product Demos
Anticipated # of Attendees	175 to 200	35 to 40	20 to 25	15 to 20
AV	Stage, podium, 2 mics	Stage, monitor, mic	Stage, Monitor, Mic	Mic and Monitor as needed
Time	50 to 60 minutes	30 minutes	15 minutes	30 to 40 minutes
Cost	\$75,000	\$15,000	\$5,000	\$12,500

* Education Schedule is still TBD

Marketing Package for Educational Opportunities

Marketing Plan A - \$14,500

- Hotel Door Drop
- Push Notification
- Registration Bag Insert
- Pre-Show Mailing List

Marketing Plan B - \$17,500

- Registration Bag Insert
- Pre-Show Mailing List
- Full-Page ad in Official Program
- Hotel Door Drop
- Push Notification

A La Carte Options

- Registration Bag Insert: \$10,000
- Hotel Door Drop: \$8,000
- Full-Page ad in Official Program: \$3,550
- Mailing List: \$1,000

Opportunities at #AAPMR21

Reach Residents

Your Opportunity... To Reach the Residents

Support three Physician-in-Training Events – PHiT Fest

- Resident Quiz Bowl
- Residents' Reception
- Resident Town Hall

Sponsorship includes:

- Recognition as a sponsor (with logo) on signage at each event, on AAPM&R website and the event Mobile App
- Reserved table at the Reception
- Ability to attend the Quiz Bowl and the Town Hall

Opportunity Cost: \$15,000

Your Opportunity... To Educate the Residents

Resident Bootcamp Sponsorship

- Taking place Thursday – Saturday, November 11-13
- Each session is 3 hours
- 2 sessions – topics to be determined
- Up to 50 attendees and 4 to 6 faculty
- There will be two bootcamps in 2021
- **Sponsorship includes:**
 - Recognition as a sponsor (with logo) on promotional materials, at the session, on AAPM&R website and the event mobile app
 - Table-top exhibit near the session
 - Ability to provide AAPM&R with a handout for all attendees
 - Ability to observe the session (2 per supporter)

Session is not CME

Opportunity Cost: \$12,500

#AAPMR 2019 Bootcamp Topics #AAPMR 2021 – Topics TBD

Resident Bootcamp 1: Ultrasound – Reviewing Essential Nerve Examination Techniques and Common Joint Injection Views (N)
Thursday, November 14: 2 pm-5 pm

Resident Bootcamp 2: Introduction to Upper Extremity Prosthetics / Lower Extremity Orthotics & Prosthetics (N)
Friday, November 15: 8 am-11 am

Resident Bootcamp 3: Spasticity Management - Reviewing Chemodenervation Techniques Including the Use of Ultrasound Guidance and Baclofen Pump Management (N)
Saturday, November 16: 2 pm-5 pm

Your Opportunity...

To Educate the Residents

- A 45-minute Education Theater held prior to the popular Job and Fellowship Fair.
- Recognition in program, Mobile App and on signage
- Up to 50 to 75 attendees
- AV included

Opportunity Cost: \$37,500



Still Need to Secure a Booth at #AAPMR21

- There is still plenty of time to secure your presence at #AAPMR21 – we are so excited to be back together again face to face.
- To view the most current Floorplan – [Click Here](#)
- To view the Exhibitor Application – [Click Here](#)

Thank you!



We value our relationship and look forward to our interactions in 2021!



Questions/Contact

Lisa Koch: Exhibits and Sponsorships

lkoch@conventusmedia.com

(617) 285-2320

Kathleen Noonan: Exhibits and Sponsorship

knoonan@conventusmedia.com

(781) 375-8584

Sharon Popielewski: Business and Resource Development/ Corporate Support

spopielewski@aapmr.org

(847) 737-6048

Video Opportunities at

aapm&r

ANNUAL ASSEMBLY 2021
NOVEMBER 11-14 • NASHVILLE, TN

aapm&r

Messaging in Key Areas

Throughout the Music City Convention Center there are 17 sets of video screens placed in the corridors of the Center. Each set contains 4 - 65" displays front to back. Each screen can display different images and/or videos.

AAPM&R has identified 7 sets of 4 (28 total video screens) in the high traffic areas where Annual Assembly is being held. The screens will run from Thursday through Sunday.

Size	4 - 65" Displays
Total Number	17
Pixel Dimensions	3840x1080
Image Format	.png, .jpg
Video Format	.mp4
Legend	◆◆

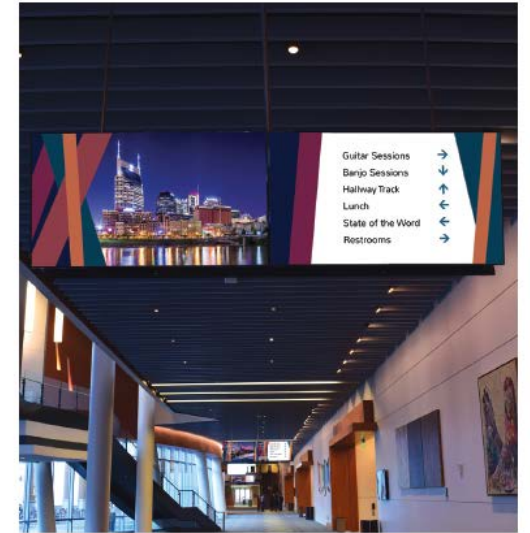

Level Two Displays



On level 2, education and skills courses will be held. There are 3 sets of 4 screens located on level 2:

- Pod 201 – S
- Pod 201 – N
- Pod 202 – S
- Pod 202 – N
- Pod 203 – S
- Pod 203 – N

Level 3 Displays

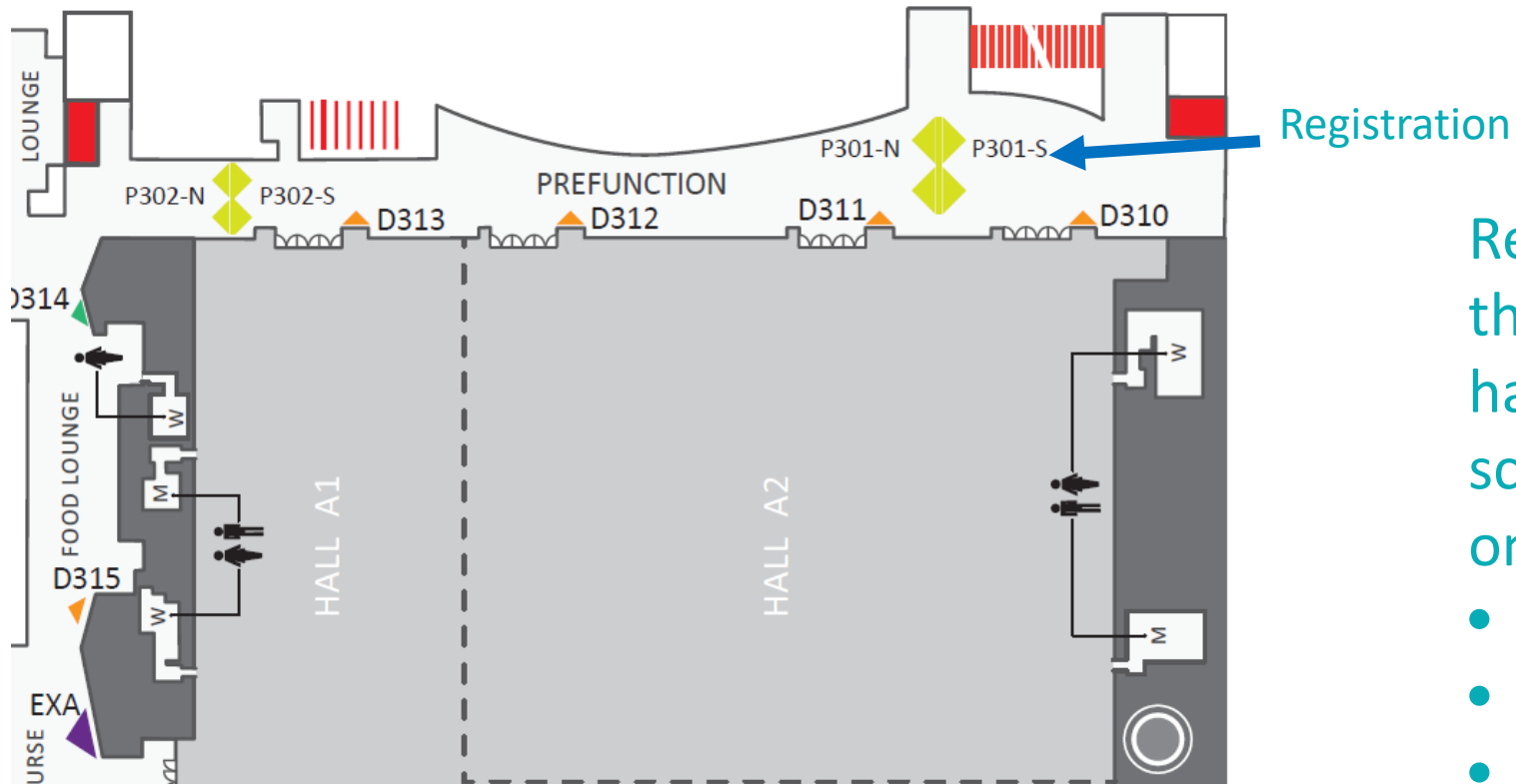

Registration is located on level three and also the exhibit halls. There are 2 sets of 4 screens identified in key areas on level 3.

- Pod 301 – N
- Pod 301 – S
- Pod 302 – N
- Pod 302 – S

Level 4 Displays

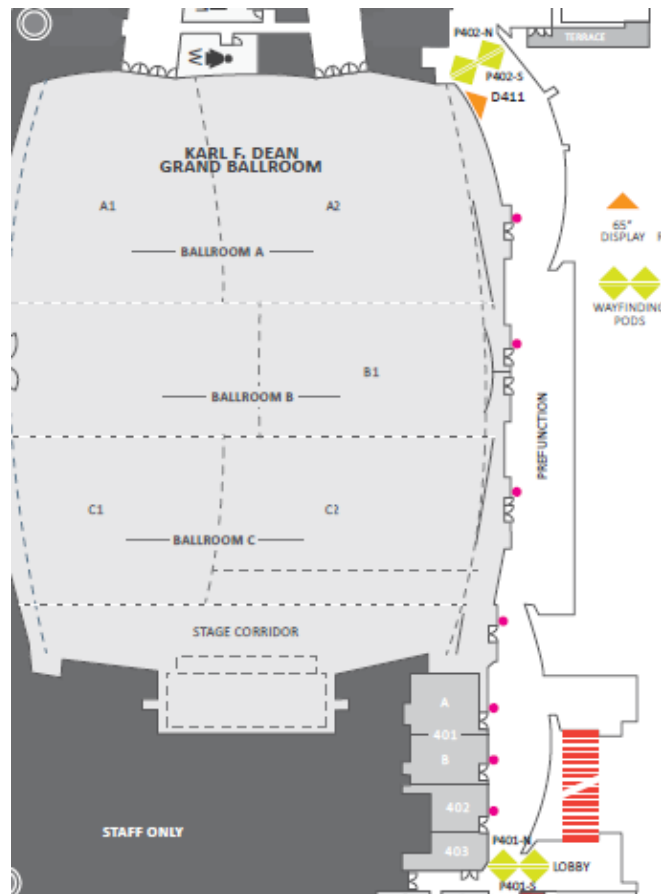

The General Sessions and other education will be held on level 4 in the Karl Dean Grand Ballroom. There are two sets of 4 video screens located on this level:

- Pod 401 – S
- Pod 401 – N
- Pod 402 – S
- Pod 402 – N

Messaging Opportunities

- Main Sponsor

Main Sponsor of the Video Screens will have the left screen exclusively. Each screen can have different images or videos. The Main Sponsor will have a total of 14 screens for their use.

- Cost: \$30,000

- Add Your Messaging

Of the 28 screens identified, messaging will run on 14 of the screens in either 30, 20 or 15 second increments. Costs are:

- 30 second spot - \$3,500
- 20 second spot - \$2,000
- 15 second spot - \$1,500

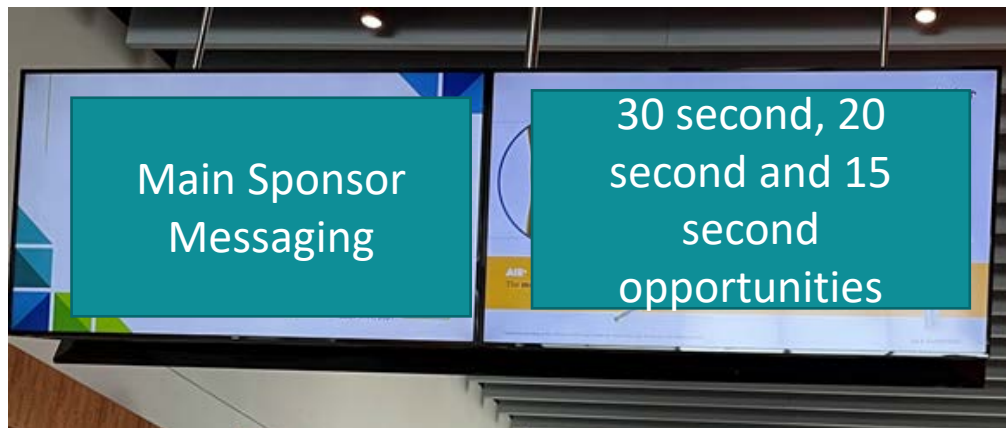

Virtual Community Sessions

Support Opportunities

aapm&r

About AAPM&R Member Communities

- AAPM&R members of all different backgrounds and experiences have a new way to connect with each other—AAPM&R Member Communities!
- Created by physiatrists, for physiatrists, Member Communities are self-identified, organically established communities offering opportunities for members to connect with each other, share experiences, and advance the future of the specialty together!
- There are currently more than 40 active member communities.
- For a list of current member communities, [visit here](#).

About AAPM&R Member Communities

What is the role of a Member Community?

- Member Communities can be:
 - Clinically focused (i.e., stroke, sports medicine, etc.)
 - Practice focused (i.e., Inpatient Rehabilitation, etc.)
 - Identity focused (i.e., African American Physiatrists, LatinX in Physiatry, Women Physiatrists, etc.)
- The focus and goals of the community are up to members of the community! A members simply completes the application process, which requires 1 designated chair to be the liaison with the Academy and a minimum of 10 community members who are AAPM&R members.

About AAPM&R Member Communities

- Resources and engagement opportunities for Member Communities are now available, and include:
 - Member Communities will have ways to connect both in-person and online:
 - NEW! A designated community on [PhyzForum](#), including an app for instant access to discussions with peers!
 - The opportunity to continue gathering in a dedicated space at the Annual Assembly.
 - Member Communities will have ways to share perspective and subject-matter expertise:
 - NEW! An opportunity to submit a proposal for a Community Session(s) as part of the Annual Assembly's program.
 - NEW! 1 representative from each Member Community will be invited to participate in the 2021 Critical PM&R Dialogues: Assembly of Delegates meeting. More details to come.

***NEW!* AAPM&R Community Weeks**

- In October 2021, AAPM&R will be hosting Community Weeks
- Community Weeks will include 32 live, virtual community sessions, open to all members
- AAPM&R will offer additional in-person networking hours in Nashville on the morning of Thursday, November 12
- Community Week sessions will take place:
 - October 11-15; Monday-Thursday 9 am-9 pm (CT); Friday 9 am-5 pm (CT)
 - October 18-22; Monday-Thursday 9 am-9 pm (CT); Friday 9 am-5 pm (CT)
 - October 25-29; Monday-Thursday 9 am-9 pm (CT); Friday 9 am-5 pm (CT)

Community Week Sessions Include*

- Adaptive Athletes and Sports & Amputee/Limb Loss Restoration Rehabilitation - Advocacy for Equitable Access to Physical Activity and Sport
- African American Physiatrists - Medicolegal Psychiatry Opportunities and African American Physiatrists
- African American Physiatrists & LatinX in Psychiatry - Critical Conversations: Recognizing and Mitigating Workplace Bullying
- Alternative Pain Medicine - Multidimensional Pain Management: Exploring Nutrition and the Mind- Body Connection (Part 1)
- Alternative Pain Medicine - Multidimensional Pain Management: Exploring Nutrition and the Mind- Body Connection (Part 2)
- Brain Injury Medicine Current Fellows and Future Candidates - Neurorehabilitation Career Paths: A Panel Discussion of the Multiple Options Your Fellowship Training Can Take You
- Business of Healthcare Physiatrists - How I Got Here: Mapping the Journey to Leadership (Part 1)
- Business of Healthcare Physiatrists - Lessons Learned on the Road to Executive Leadership (Part 2)
- Cancer Rehabilitation - Advocacy, Telemedicine, and Experiences During COVID-19
- Cancer Rehabilitation Medicine & Pediatric Rehabilitation - Building Pediatric Cancer Rehabilitation Programs: Pearls and Pitfalls of Program Development (Part 1)
- Cancer Rehabilitation Medicine & Pediatric Rehabilitation - Multidisciplinary Case Studies in Pediatric Cancer Rehabilitation (Part 2)
- Central Nervous System - Adult Rehabilitation Care of Persons Aging with Acquired CNS Disorders and Neurodevelopmental Disabilities (Part 1)
- Central Nervous System - Transition of Care: Neurorehabilitation Journey Through Different Settings of Healthcare (Part 2)
- Central Nervous System & Pediatric Rehabilitation - "Dear Physiatrist" Let's Talk about Transition of Care for People with Acquired and Developmental Disabilities
- Exercise as Medicine - From Lab to Practice - Translating Science into Programmatic Enhancements
- Geriatric Rehabilitation - Hot Topics in Geriatrics and Rehabilitation
- Inpatient Consultants - PM&R Consultations: More Than Just Dispo..
- Inpatient Rehabilitation - Hotbeds of Infection: Preventing Outbreaks on the Rehab Unit
- LGBTQIA+ in Psychiatry - Inaugural Community Networking Session
- Medical Educators - Diversity and Inclusion in the PM&R Medical Education
- Muslim Physiatrists - Principles of Assessment: Providing Feedback
- Neuromodulation, Pain Medicine & Spine Medicine - Pain and Spine Community Session
- Pediatric Rehabilitation - Cerebral Palsy Challenges: Dystonia, Sexuality and Intimacy, and Mimickers
- Pediatric Sports Medicine - Concussion Management in Children With and Without Disabilities
- Performing Arts Medicine - Community (Part 2)
- Performing Arts Medicine - Community (Part 1)
- Psychiatry in Skilled Nursing Facilities - Physiatric Practice in the SNF: Success During and After the COVID Pandemic
- Research in Psychiatry - Opportunities to Engage in and Optimize Quality of Psychiatry Research
- Running Medicine - New Evidence on Clinical Exam, Functional Assessment and Injury Prevention in Runners
- South Asian Psychiatry - COVID Across the Continents: A Panel Discussion
- Sports Medicine - Prevention Strategies of Common Sports Injuries
- Women Physiatrists - How to Navigate Business in Medicine

*Subject to change

Get In Front of Targeted Community Members

SPONSORSHIP OF EACH COMMUNITY GIVES YOU THE FOLLOWING VALUES:

- Ability to provide a recorded video to be sent to community members twice (up to 30 seconds)
- Ability to provide a handout (pdf) or link to a supporter-created resource to be included in the informational email sent to registrants (information will be sent twice)
- Recognition on signage at the Annual Assembly and in the virtual platform
- Recognition as an AAPM&R Community Supporter on the AAPM&R website, in membership publications, on AAPM&R social media channels

Sponsorship cost: \$5,000 per Community

Sponsor all Communities: \$30,000

Thank You For Your Consideration

For questions or comments, please contact:

Kathleen Noonan, Conventus Media

P: (781) 375-8584

E: knoonan@conventusmedia.com